

Pressure Sensors

Low-cost, Stainless Steel Transducers

SPT Series

FEATURES

- Reliable semiconductor technology
- Calibrated and temperature compensated
- Rugged, stainless steel package
- NEMA 4 design
- Small size
- Absolute, gage, sealed gage, vacuum gage pressures
- 0 psi to 3 psi, 0 psi to 5000 psi

TYPICAL APPLICATIONS

- Industrial automation and flow control
- Pressure instrumentation
- Hydraulic systems
- Process control



Honeywell's SPT Series stainless steel pressure sensors are designed for pressure applications that involve measurement of hostile media in harsh environments and will accommodate any media that will not adversely attack 304 or 316 stainless steel wetted parts.

The SPT Series is calibrated and compensated for three styles of output: 4.0 mA to 20.0 mA (mA version); 1.0 Vdc to 5.0 Vdc (4 V version); and 0 mV to 100 mV (mV version). All versions feature a variety of pressure connections to allow use in a wide range of OEM (Original Equipment Manufacturer) equipment.

The SPT Series stainless steel devices are rugged and reliable transducers for use in a wide variety of pressure sensing applications where corrosive liquids and gases are monitored.

EQUIVALENT BASIC CIRCUIT

SPT mA

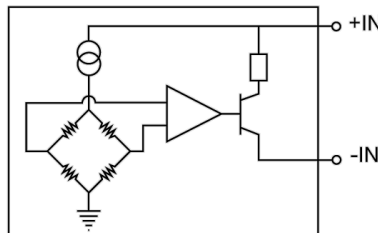

SPT 4V

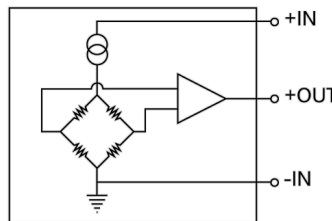

SPT mV

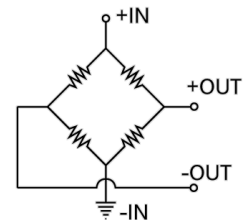

⚠ WARNING

PERSONAL INJURY

DO NOT USE these products as safety or emergency stop devices or in any other application where failure of the product could result in personal injury.

Failure to comply with these instructions could result in death or serious injury.

⚠ WARNING

MISUSE OF DOCUMENTATION

- The information presented in this product sheet is for reference only. Do not use this document as a product installation guide.
- Complete installation, operation, and maintenance information is provided in the instructions supplied with each product.

Failure to comply with these instructions could result in death or serious injury.

Pressure Sensors

Low-cost, Stainless Steel Transducers

SPT Series

PRESSURE TRANSDUCER CHARACTERISTICS – ALL DEVICES

Environmental Specifications

Compensated temperature range	-10 °C to 85 °C [14 °F to 185 °F]
Operating temperature range	-40 °C to 85 °C [-40 °F to 185 °F]
Storage temperature range	-40 °C to 85 °C [-40 °F to 185 °F]
Vibration	10 G at 20 Hz to 2000 Hz
Shock	100 G for 11 ms
Life	1 million cycles min.
Insulation resistance	100 MΩ at 50 Vdc

Recommended Supply Range

SPT mA	Supply voltage $V_s = +10$ Vdc to +24 Vdc
SPT 4V	Supply voltage $V_s = +10$ Vdc to +24 Vdc Quiescent current $I_{QSC} = 5$ mA Short circuit current $I_{SC} = 18$ mA
SPT mV	Supply voltage $V_s = +10$ Vdc

Maximum Supply Ratings

SPT mV	Supply voltage $V_s = +15$ Vdc
SPT mA and SPT 4V	Supply voltage $V_s = +24$ Vdc

PRESSURE RANGE SPECIFICATIONS – ALL DEVICES

Catalog Listing*	Pressure range	Proof pressure ⁽⁷⁾	Burst pressure ⁽⁸⁾
SPT (mA, mV, 4V) 0003P G (4,5,6,7,9) (B/WXX)	0 psig to 3 psig	9 psig	15 psig
SPT (mA, mV, 4V) 0005P G (4,5,6,7,9) (B/WXX)	0 psig to 5 psig	15 psig	25 psig
SPT (mA, mV, 4V) 0010P G (4,5,6,7,9) (B/WXX)	0 psig to 10 psig	30 psig	50 psig
SPT (mA, mV, 4V) 0015P (A,G,V) (4,5,6,7,9) (B/WXX)	0 psi to 15 psi	45 psi	75 psi
SPT (mA, mV, 4V) 0030P (A,G,V) (4,5,6,7,9) (B/WXX)	0 psi to 30 psi	90 psi	150 psi
SPT (mA, mV, 4V) 0050P (A,G,V) (4,5,6,7,9) (B/WXX)	0 psi to 50 psi	150 psi	250 psi
SPT (mA, mV, 4V) 0100P (A,G,V) (4,5,6,7,9) (B/WXX)	0 psi to 100 psi	300 psi	500 psi
SPT (mA, mV, 4V) 0200P (A,G,V) (4,5,6,7,9) (B/WXX)	0 psi to 200 psi	600 psi	1000 psi
SPT (mA, mV, 4V) 0300P (A,G,V) (4,5,6,7,9) (B/WXX)	0 psi to 300 psi	900 psi	1500 psi
SPT (mA, mV, 4V) 0500P (A,G,V) (4,5,6,7,9) (B/WXX)	0 psi to 500 psi	1200 psi	2400 psi
SPT (mA, mV, 4V) 1000P (A,S) (4,5,6,7) (B/WXX)	0 psi to 1000 psi	3000 psia	5000 psia
SPT (mA, mV, 4V) 2000P (A,S) (4,5,6,7) (B/WXX)	0 psi to 2000 psi	6000 psia	10000 psia
SPT (mA, mV, 4V) 3000P (A,S) (4,5,6,7) (B/WXX)	0 psi to 3000 psi	9000 psia	10000 psia
SPT (mA, mV, 4V) 5000P (A,S) (4,5,6,7) (B/WXX)	0 psi to 5000 psi	10000 psia	10000 psia

* Note: Vacuum gage units (V option) allow you to pull a hard vacuum on the gage units. Vacuum gage parts are only available on the mV version in 15 psig through 500 psig. As sold, this package design is not submersible. In order to make the package submersible, package needs to be sealed.

NOTES

- The maximum pressure that can be applied without changing the transducer's performance or accuracy.
- The maximum pressure that can be applied to a transducer without rupture of either the sensing element or transducer case.

Pressure Transducers

Low-cost, Stainless Steel Transducers

SPT Series

PERFORMANCE CHARACTERISTICS ⁽¹⁾

SPT mV Series	Minimum	Typical	Maximum	Unit
Zero pressure offset	-2	0	+2	mV
Full-scale span (0 psig to 3 psig and 0 psig-5 psig only) ⁽²⁾	48	50	52	mV
Full-scale span (0 psi to 10 psi and 0 psi to 3000 psi only) ⁽²⁾	98	100	102	mV
Full-scale span (0 psi to 5000 psi only) ⁽²⁾	148	150	152	mV
Pressure non-linearity ⁽³⁾	–	±0.1	±0.25	%FSS
Pressure hysteresis ⁽³⁾	–	±0.015	±0.030	%FSS
Repeatability	–	±0.010	±0.030	%FSS
Temp. effect on span ⁽⁴⁾	–	±0.5	±1.0	%FSS
Temp. effect on offset ⁽⁴⁾	–	±0.5	±1.0	%FSS
Temp. effect on span (0 psi to 3 psi and 0 psi to 5 psi only) ⁽⁴⁾	–	±1	±2.0	%FSS
Temp. effect on offset (0 psi to 3 psi and 0 psi to 5 psi only) ⁽⁴⁾	–	±1	±2.0	%FSS
Thermal hysteresis (-10 °C to 85 °C [14 °F to 185 °F])	–	±0.1	±0.3	%FSS
Long-term stability of offset and span ⁽⁵⁾	–	±0.1	±0.3	%FSS
Response time ⁽⁶⁾	–	0.1	–	ms
Common mode voltage (voltage version “K”) ⁽⁹⁾	0.5	1.25	2.0	Vdc
Input resistance	8.0	25	50	kΩ
Output resistance	3.0	4.5	6.0	kΩ
SPT mA Series				
Zero pressure offset	3.84	4.0	4.16	mA
Full-scale span ⁽²⁾	15.84	16.0	16.16	mA
Pressure non-linearity ⁽³⁾	–	±0.1	±0.25	%FSS
Pressure hysteresis ⁽³⁾	–	±0.015	±0.03	%FSS
Repeatability	–	±0.010	±0.030	%FSS
Temp. effect on span ⁽⁴⁾	–	±0.5	±1.5	%FSS
Temp. effect on offset ⁽⁴⁾	–	±0.5	±1.5	%FSS
Temp. effect on span (0 psi to 3 psi and 0 psi to 5 psi only) ⁽⁴⁾	–	±1.5	±2.5	%FSS
Temp. effect on offset (0 psi to 3 psi and 0 psi to 5 psi only) ⁽⁴⁾	–	±1.5	±2.5	%FSS
Thermal hysteresis -10 °C to 85 °C [14 °F to 185 °F]	–	±0.1	±0.3	%FSS
Long term stability of offset and span ⁽⁵⁾	–	±0.1	±0.3	%FSS
Response time ⁽⁶⁾	–	5	–	ms
SPT 4V Series				
Zero pressure offset	0.96	1.0	1.04	V
Full-scale span ⁽²⁾	3.96	4.0	4.04	V
Pressure non-linearity ⁽³⁾	–	±0.1	±0.25	%FSS
Pressure hysteresis ⁽³⁾	–	±0.015	±0.03	%FSS
Repeatability	–	±0.010	±0.030	%FSS
Temp. effect on span ⁽⁴⁾	–	±0.5	±1.5	%FSS
Temp. effect on offset ⁽⁴⁾	–	±0.5	±1.5	%FSS
Temp. effect on span (0 psi to 3 psi and 0 psi to 5 psi only) ⁽⁴⁾	–	±1.5	±2.5	%FSS
Temp. effect on offset (0 psi to 3 psi and 0 psi to 5 psi only) ⁽⁴⁾	–	±1.5	±2.5	%FSS
Thermal hysteresis -10 °C to 85 °C [14 °F to 185 °F]	–	±0.1	±0.3	%FSS
Long term stability of offset and span ⁽⁵⁾	–	±0.1	±0.3	%FSS
Response time ⁽⁶⁾	–	5	–	ms

NOTES

- Reference conditions (unless otherwise noted): $T_a = 25\text{ °C}$ [77 °F]; Supply $V_s = 24\text{ Vdc} \pm 0.01\text{ Vdc}$.
- Full-scale span (FSS) is the algebraic difference between the output voltage at full-scale positive pressure and the output at zero pressure. FSS is ratiometric to the supply voltage.
- Pressure non-linearity is based on best-fit straight line from zero to the full-scale pressure. Pressure hysteresis is the maximum output difference at any point within the operating pressure range for increasing and decreasing pressure.
- Maximum error band of the offset voltage or span over the compensated temperature range, relative to the 25 °C [77 °F] reading.
- Long-term stability over a six-month period.
- Response time for a 0 psi to FSS pressure step change, 10 % to 90 % rise time.
- Common mode voltage as measure from output to ground.

Pressure Sensors

Low-cost, Stainless Steel Transducers

SPT Series

SPT mA SERIES EXTERNAL LOAD LINE

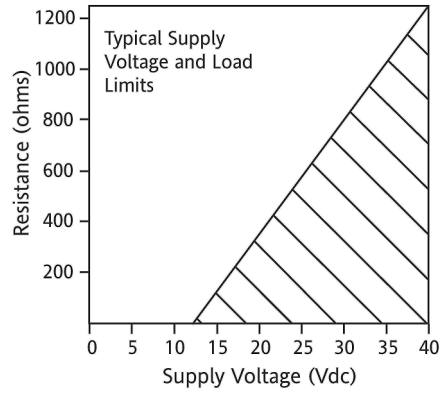

PHYSICAL DIMENSIONS for reference only, in (mm)

PACKAGE 4: 1/8 NPT Port

VERSION B (Bayonet Connector)

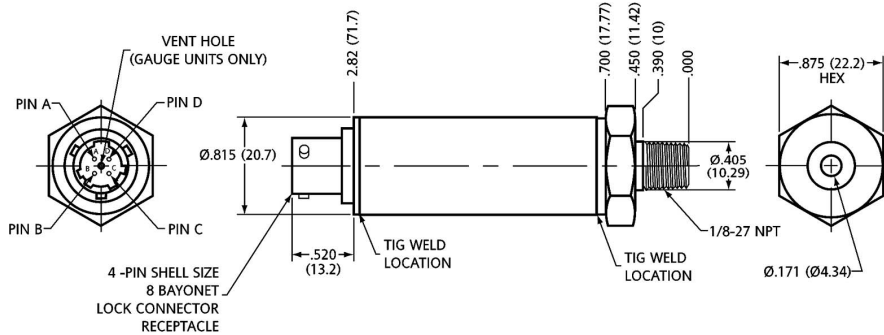

VERSION W (Pigtail Cable Connection)

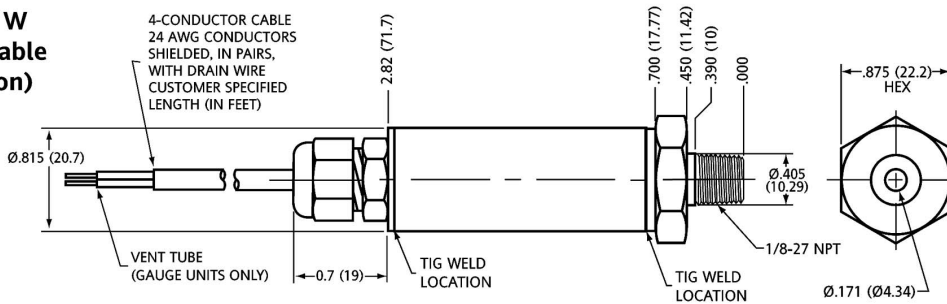

THE FOLLOWING TABLES APPLY TO ALL DRAWINGS

PIN DESIGNATIONS			
PIN LTR	mA	4V	mV
A	+IN	+IN	+IN
B	N/C	+OUT	+OUT
C	N/C	N/C	-OUT
D	-IN	-IN	-IN

WIRE CODE			
Color	mA	4V	mV
RED	+IN	+IN	+IN
BLACK	-IN	-IN	-IN
GREEN	N/C	+OUT	+OUT
WHITE	N/C	N/C	-OUT
BARE	SHIELD	SHIELD	SHIELD

Pressure Sensors

Low-cost, Stainless Steel Transducers

SPT Series

Package 4: 1/4 NPT Port

VERSION B (Bayonet Connector)

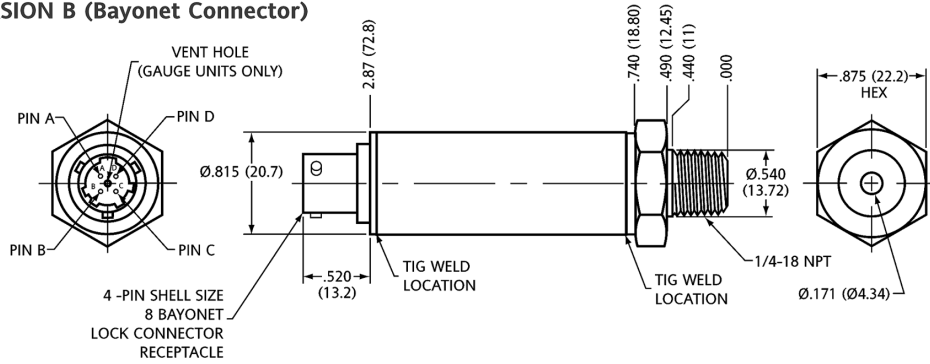

VERSION W (Pigtail Cable Connection)

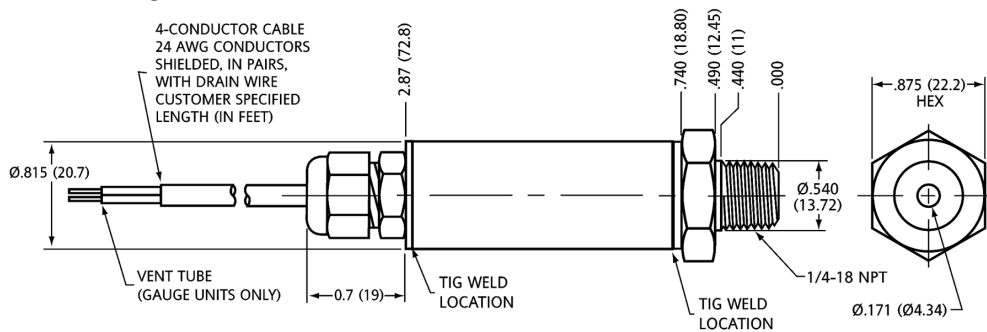

PACKAGE 6: 7/16-20 UNF Port

VERSION B (Bayonet Connector)

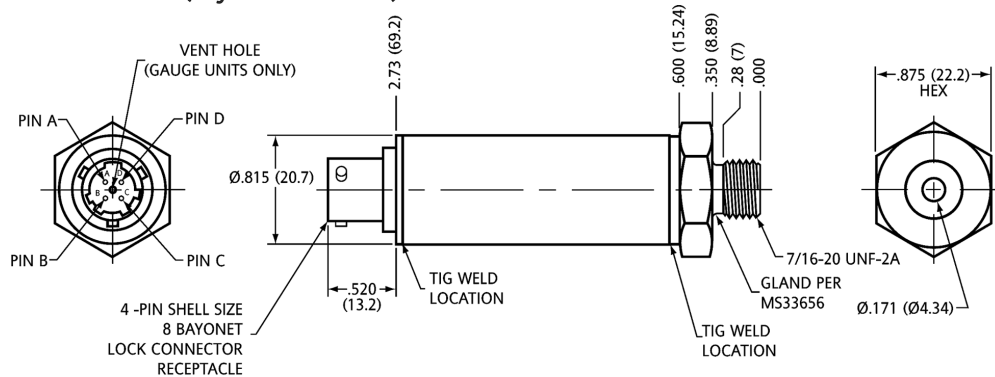

VERSION W (Pigtail Cable Connection)

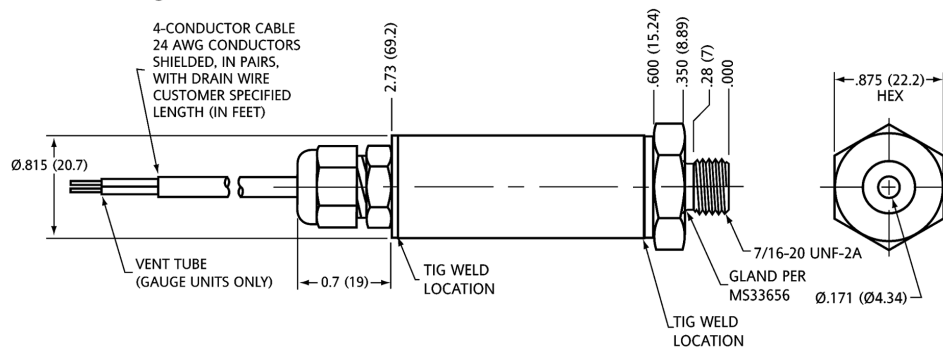

Pressure Sensors

Low-cost, Stainless Steel Transducers

SPT Series

PACKAGE 7: 1/4-19 BSPP Port

VERSION B (Bayonet Connector)

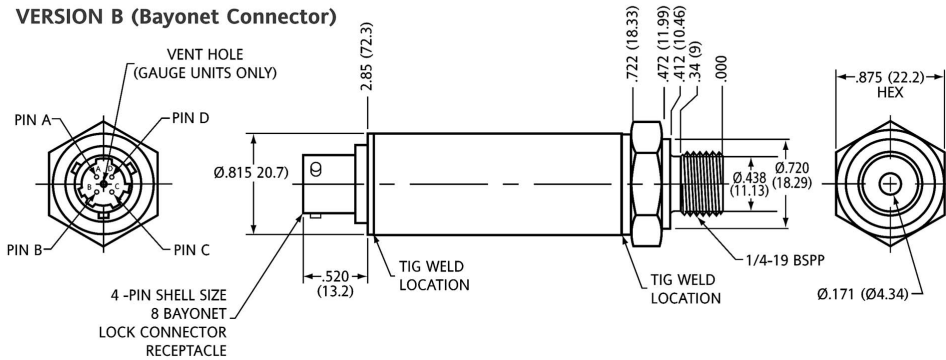

VERSION W (Pigtail Cable Connection)

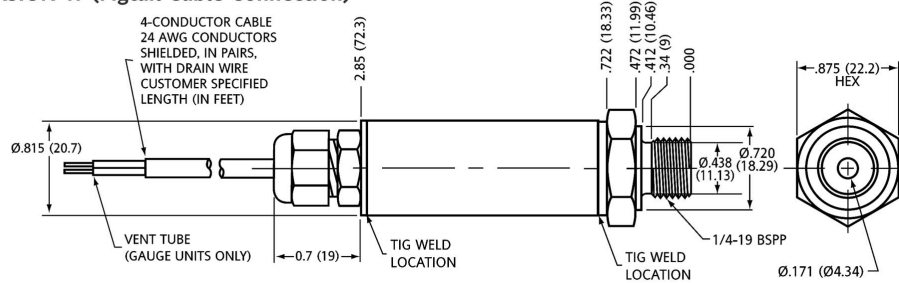

PACKAGE 9: VCR Port

VERSION B (Bayonet Connector)

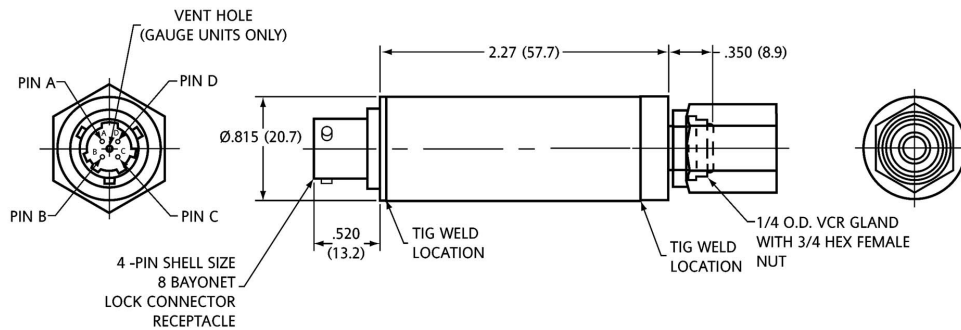

VERSION W (Pigtail Cable Connection)

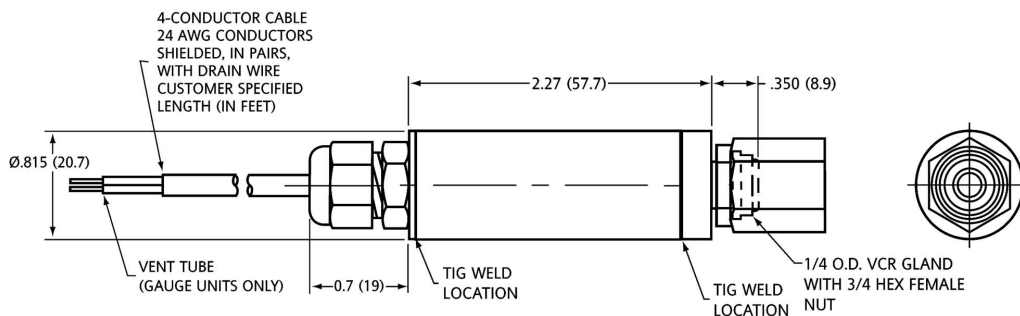

Pressure Sensors

Low-cost, Stainless Steel Transducers

SPT Series

ORDERING INFORMATION

SPT mA Series

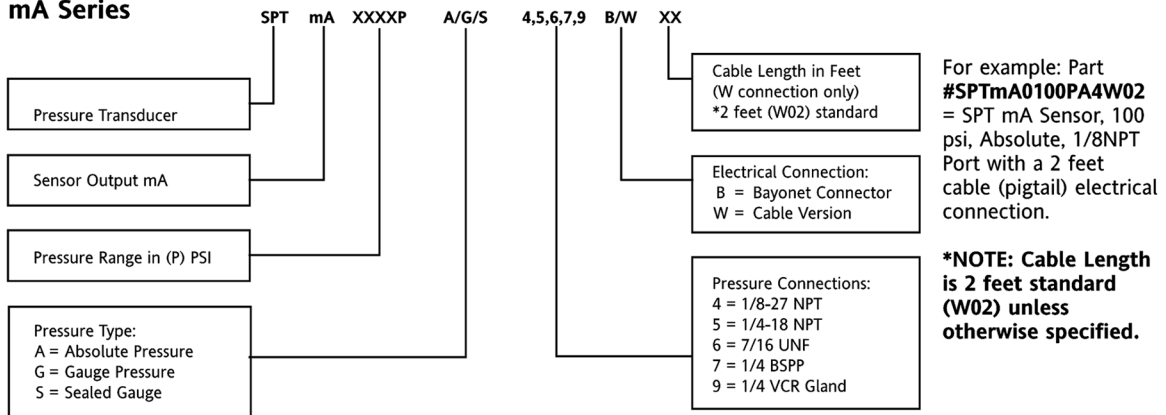

SPT mV Series

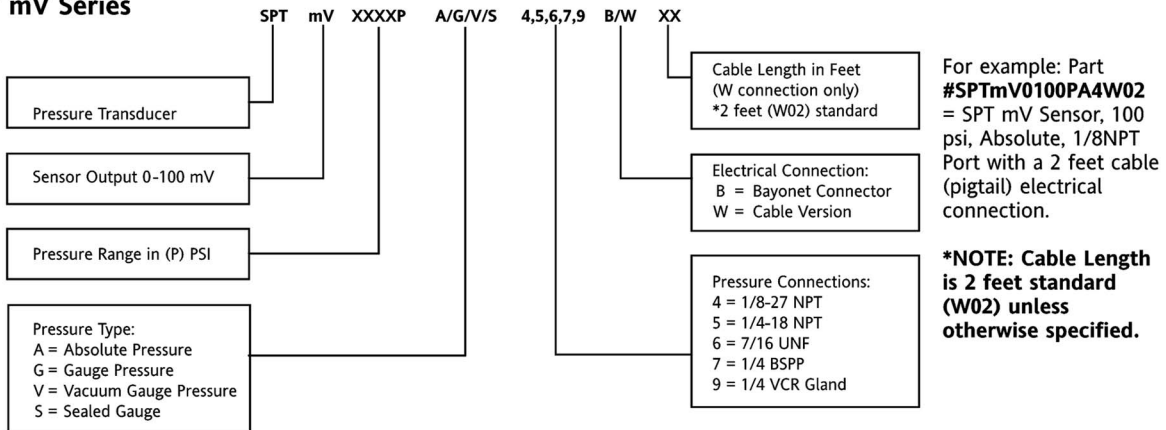

SPT 4V Series

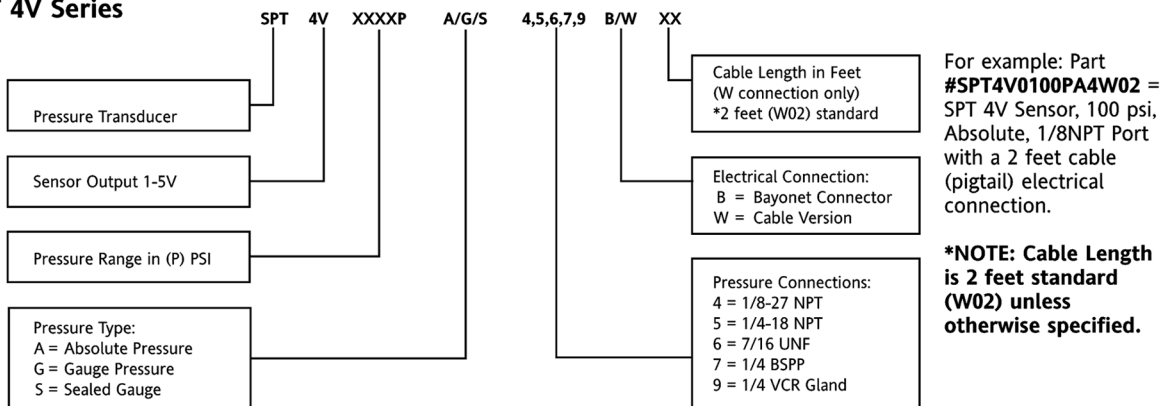

Pressure Sensors

Low-cost, Stainless Steel Transducers

SPT Series

WARRANTY/REMEDY

Honeywell warrants goods of its manufacture as being free of defective materials and faulty workmanship. Contact your local sales office for warranty information. If warranted goods are returned to Honeywell during the period of coverage, Honeywell will repair or replace without charge those items it finds defective. **The foregoing is Buyer's sole remedy and is in lieu of all other warranties, expressed or implied, including those of merchantability and fitness for a particular purpose.**

Specifications may change without notice. The information we supply is believed to be accurate and reliable as of this printing. However, we assume no responsibility for its use.

While we provide application assistance personally, through our literature and the Honeywell web site, it is up to the customer to determine the suitability of the product in the application. For application assistance, current specifications, or name of the nearest Authorized Distributor, contact a nearby sales office. Or call:

1-800-537-6945 USA/Canada

1-815-235-6847 International

FAX

1-815-235-6545 USA

INTERNET

www.honeywell.com/sensing

info.sc@honeywell.com

Honeywell

Sensing and Control

www.honeywell.com/sensing

Honeywell

11 West Spring Street

Freeport, Illinois 61032